



4080LPT

Tele wheel loader



Technical specifications

Engine data

Manufacturer	Deutz
Engine type	TCD 2.9 L4
Cylinders	4
Engine performance (max.)	55.4 (75) kW (hp)
at rpm (max.)	2300 rpm
Cubic capacity	2900 cm ³
Cooling system	Water/charge air

Electrical system

Operating voltage	12 V
-------------------	------



Battery	95 Ah
Alternator	95 A
Weights	
Operating weight (standard)	6000 kg
Lift force (max.)	4.428 daN
Tipping load with bucket - machine straight	3413 (1946*) kg
Tipping load with pallet fork - machine straight	3100 (1868*) kg
Vehicle data	
Axle	PA 1422
Cab (optional)	FSD (cabin)
Ground speed (optional)	0–20 (30) km/h
Speed stages	2
Fuel tank capacity	82 l
Hydraulic oil tank capacity	66 l
Hydraulic system	
External services - Operating pressure	445 bar
Steering hydraulics - Oil flow (optional)	64 (73–103) l/min
Steering hydraulics - Operating pressure	235 bar
Drive	
Type of drive	Hydrostatic
Traction drive	Universal joint shaft
Noise values	
Guaranteed sound power level L _{WA}	101 dB(A)

* extended

Tipping load calculation according to ISO 14397

FSD = overhead guard

Vibrations (weighted average effective value)

Hand-arm vibrations (HAV): The hand-arm vibrations are no more than 2.5 m/s²

Whole body vibrations: This machine is equipped with a driver's seat that meets the requirements of EN ISO 7096:2000.

When

the loader is in accordance with the intended purpose, the whole body

vibrations vary from below 0.5 m/s² up to a short-term



maximum value.

It is recommended to use the values

specified in the table when calculating the vibration values

according to ISO/TR 25398:2006. At the same time the actual use conditions have to be taken into

consideration.

Tele wheel loaders, like wheel loaders, are to be classified by operating weight.

Type of loader	Typical operating conditions	Average value			Standard deviation (s)		
		$1.4 \cdot a_{w,eqx}$	$1.4 \cdot a_{w,eqy}$	$a_{w,eqz}$	$1.4 \cdot s_x$	$1.4 \cdot s_y$	s_z
		[m/s ²]	[m/s ²]	[m/s ²]	[m/s ²]	[m/s ²]	[m/s ²]
Compact wheel loader (operating weight < 4,500 kg)	Load & carry (load and transport work)	0.94	0.86	0.65	0.27	0.29	0.13
Wheel loader (operating weight > 4,500 kg)	Load & carry (load and transport work)	0.84	0.81	0.52	0.23	0.2	0.14
	Application in extraction (harsh application conditions)	1.27	0.97	0.81	0.47	0.31	0.47
	Transfer drive	0.76	0.91	0.49	0.33	0.35	0.17
	V-operation	0.99	0.84	0.54	0.29	0.32	0.14



4080LPT

Tele wheel loader

Dimensions

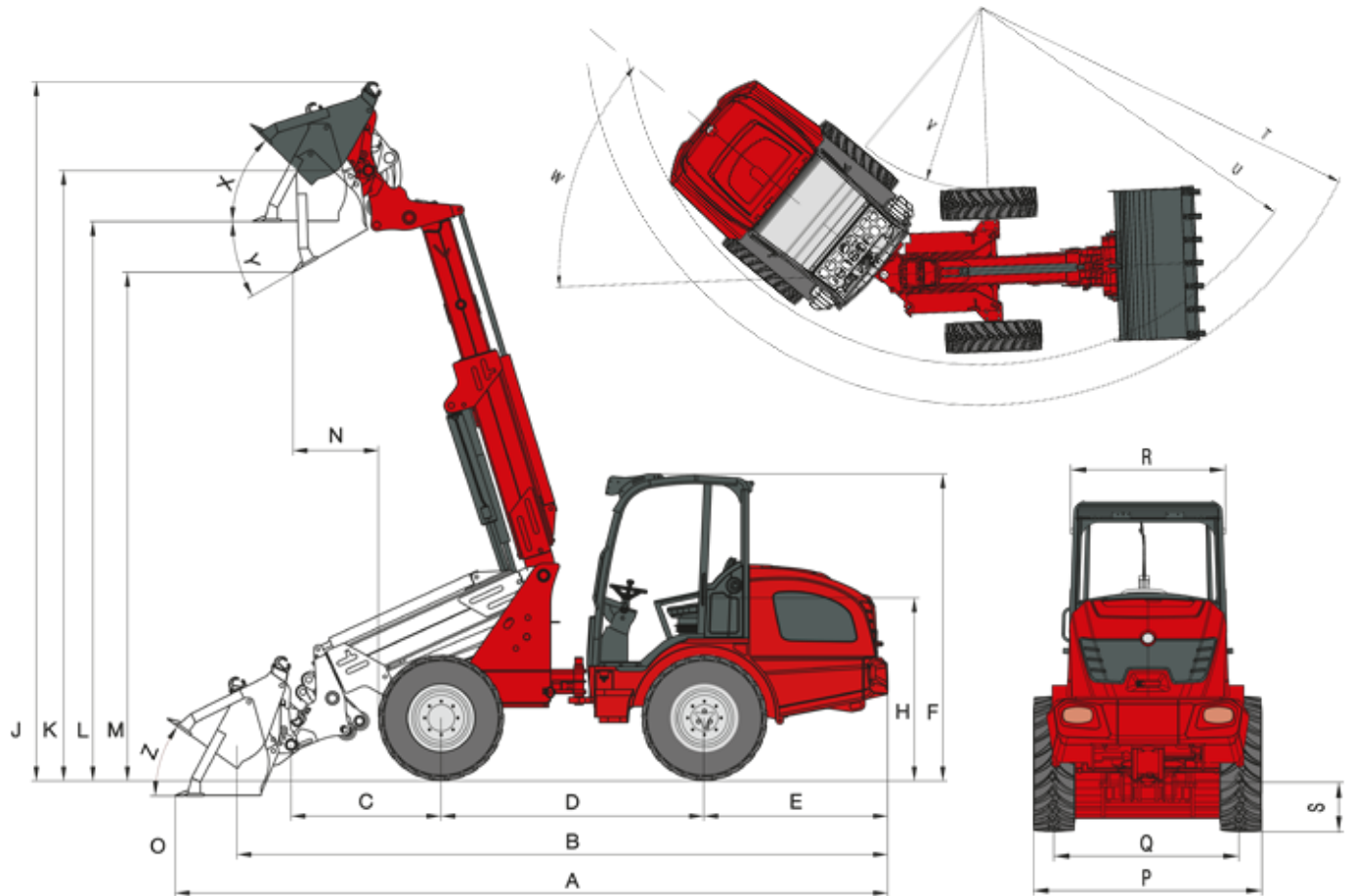

A	Total length	5.929 mm
B	Total length (without bucket)	5.180 mm
C	Axle middle to bucket pivot pin	1394 mm
D	Wheelbase	2.189 mm
E	Rear overhang	1.531 mm
F	Height to top of overhead guard - high-profile	2.495 mm
	Height to top of cabin - high-profile	2.532 mm



H	Seat top height	1.495 mm
J	Total working height	5.815 mm
K	Height of bucket pivot (max.)	5.076 mm
L	Load-over height	4.651 mm
M	Dumping height	4.229 mm
N	Operating distance for M	707 mm
O	Digging depth	126 mm
P	Total width	1.742 mm
Q	Track width	1.432 mm
S	Ground clearance	410 mm
T	Maximum radius external	4.275 mm
U	Radius at the outer edge	3.840 mm
V	Inside turning radius	1.948 mm
W	Inclination angle	42 °
X	Rollback angle at max. lifting height	45 °
Y	Dumping angle (max.)	30 °
Z	Rollback angle (on the ground)	36 °



4080LPT

Tele wheel loader

Standard components

Motor

- Deutz TCD 2.9 L4 (55.4 kW/75 hp)

Drive system

- Planetary axle PA1422
- Hydrostatic all-wheel drive, travel direction can be selected via joystick
- Service brake: Hydrostatic drive system acting on all 4 wheels (wear-free)
- Central service and parking brake in the drive train acting on all 4 wheels
- 100% differential lock, electric-hydraulically connectable on front and rear axle
- Tyres 12.5–20 MPT ETO

Steering system

- Hydraulic articulated pendulum steering, 12° oscillating angle

Hydraulics

- 3rd control circuit front DN12
- Hydraulic oil cooler
- Unpressurised front reverse travel
- Floating position for lift cylinder
- Lock for steering valve

Driver's cabin

- "Tall" overhead guard (height 2,495 mm) with front and rear window, roll-over protective structure/FOPS tested
- Comfort seat with safety belt, fully suspended, weight, back and horizontal adjustment
- Joystick with direction control switch and integrated touch button for differential lock and telescoping function
- Adjustable steering column

Kinematics

- Telescope arm

Other

- Working lights (2 front, 2 rear)
- Plug receptacle in front, 3-pin (dual function)
- Load-lowering valve
- Operating hour meter
- Battery isolator switch
- Fuel display
- Hydraulic quick-change system for attachments



4080LPT

Tele wheel loader

Options

Motor

- Deutz TCD 2.9 L4 (55.4 kW/75 hp) with diesel particulate filter
- Engine pre-heater/hydraulic oil pre-heater

Driver's cabin

- "Tall" 2-door cabin, including heating and ventilation (height 2,532 mm)
- "Tall" 1-door cabin, including heating and ventilation (height 2,532 mm)
- Air-cushioned comfort seat (fabric/artificial leather)
- Heated seat
- Radio

Lighting

- Lighting according to Road Traffic Regulations
- Rotating beacon
- MEGA working lights (2 front, 2 rear)
- LED working lights (2 front, 2 rear)

Drive system

- Speed increase to 30 km/h
- Hand inching

Hydraulics

- Work hydraulics of large pump (73–103 l/min)
- Reversing valve in front on 3rd control circuit (3rd control circuit with 4 connections)
- 3rd control circuit proportional, including double notch via switch
- Notch for joystick (single)
- Rear unpressurised return line
- Hydro connection in rear is dual-acting via reversing valve (l/min like 3rd control circuit in front)
- Dual-acting hydraulic connection in rear (51 l/min) (two couplings), including separate steering valve
- 2x hydraulic connection in rear (51 l/min) dual acting (four couplings), including separate steering valve

Electrical connections

- Plug receptacle for rear attachments, 7-pin
- Triple-pole rear plug receptacle

Other

- Reversing warning system
- Ballast weight (floor plate 118 kg)
- Combination case with warning triangle and first-aid kit



- Tool box
- Technical Inspection Authority expert's report
- Fully automatic central lubrication unit
- Custommade paint finish
- Hand lever grease gun
- Load vibration dampening
- Self-recovery coupling

Please note

that product availability can vary from country to country. It is possible that information / products may not be available in your country. More detailed information on engine power can be found in the operator's manual; the stated power may vary due to specific operating conditions.

Subject to alterations and errors excepted. Applicable also to illustrations.

Copyright © 2017 Weidemann GmbH.