



5080

Wheel loader



Technical specifications

Engine data Standard

Manufacturer	Perkins
Engine type	854F-E34TA
Cylinders	4
Engine performance (max.)	55.4 (75) kW (hp)
at rpm (max.)	2200 rpm
Cubic capacity	3400 cm ³
Cooling system	Water $\frac{1}{2}$ / $\frac{1}{2}$ charge air
Abgasnormstufe	IIIB
Abgasnachbehandlung	DPF



Engine data Option

Manufacturer	Perkins
Engine type	854F-E34TA
Cylinders	4
Engine performance (max.) at rpm (max.)	90 (122) kW (hp) 2200 rpm
Cubic capacity	3400 cm ³
Cooling system	Water ² / ₂ charge air
Abgasnormstufe	IV
Abgasnachbehandlung	DOC+SCR

Electrical system

Operating voltage	12 V
Battery	95 Ah
Alternator	120 A

Weights

Operating weight (standard)	7000 kg
Tipping load with bucket - machine straight	4762 kg
Tipping load with bucket - machine articulated	3926 kg
Tipping load with pallet fork - machine straight	4254 kg
Tipping load with pallet fork - machine articulated	3559 kg

Vehicle data

Axle	PA 1422/2
Cab	Cabin
Ground speed (optional)	0- 20 (30, 40) km/h
Speed stages	2
Fuel tank capacity	105 l
Hydraulic oil tank capacity	95 l

Hydraulic system

External services - Operating pressure	445 bar
Steering hydraulics - Oil flow (optional)	100 (115-150) l/min
Steering hydraulics - Operating pressure	210 bar

Drive

Type of drive	Hydrostatic
Traction drive	Universal joint shaft

Noise values



Guaranteed sound power level L _{WA}	103 dB(A)
Specified sound pressure level L _{pA}	78 dB(A)

Tipping load calculation according to ISO 14397 (horizontal mast)

DPF = Diesel particulate filter

DOC = Diesel oxidation catalytic converter

SCR = Selective catalytic reduction

Vibrations (weighted average effective value)

Hand-arm vibrations: The hand-arm vibrations are no more than 2.5 m/s²

Whole-body vibrations: This machine is equipped with a operator's seat that meets the requirements of EN ISO 7096:2000.

When the loader is properly used, the whole body vibrations vary from below 0.5 m/s² up to a short-term maximum value.

It is recommended to use the values specified in the table when calculating the vibration values according to ISO/TR 25398:2006. At the same time, the actual use conditions have to be taken into consideration.

Telehandlers, like wheel loaders, are to be classified by operating weight.

Type of loader	Typical operating conditions	Mean value			Standard deviation (s)		
		1.4*a _{w,eqx} [m/s ²]	1.4*a _{w,eqy} [m/s ²]	a _{w,eqz} [m/s ²]	1.4*s _x [m/s ²]	1.4*s _y [m/s ²]	s _z [m/s ²]
Compact wheel loader (operating weight < 4,500 kg)	Load & carry (load and transport work)	0.94	0.86	0.65	0.27	0.29	0.13
Wheel loader (operating weight > 4,500 kg)	Load & carry (load and transport work)	0.84	0.81	0.52	0.23	0.2	0.14
	Application in extraction (harsh application conditions)	1.27	0.97	0.81	0.47	0.31	0.47
	Delivery drive	0.76	0.91	0.49	0.33	0.35	0.17
	V-operation	0.99	0.84	0.54	0.29	0.32	0.14



5080

Wheel loader

Dimensions

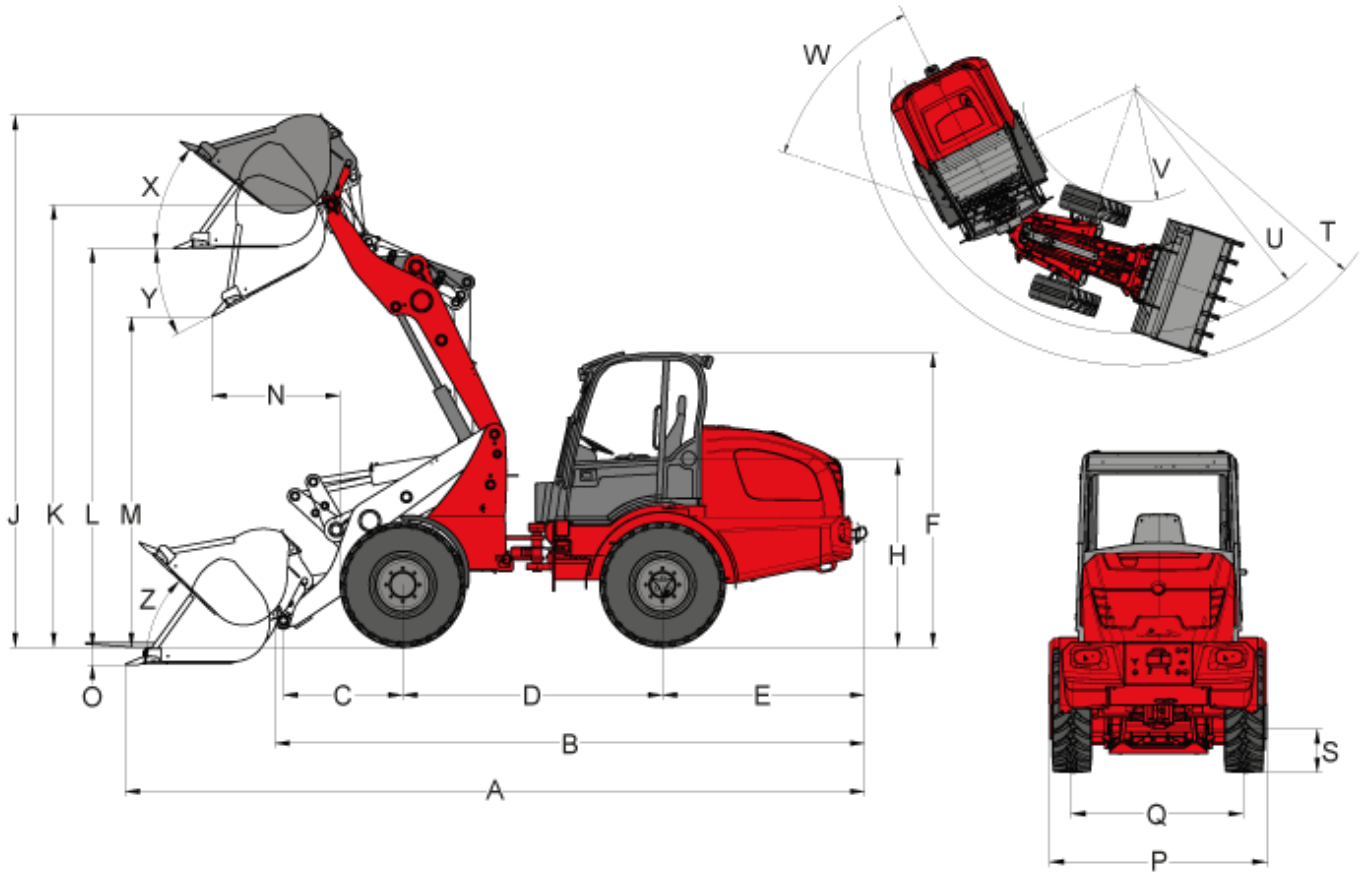

A	Total length	6.127 mm
B	Total length (without bucket)	4.886 mm
C	Axle middle to bucket pivot pin	990 mm
D	Wheelbase	2.151 mm
E	Rear overhang	1.676 mm
F	Height to top of cabin	2.694 mm
H	Seat top height	1.570 mm



J	Total working height	4.428 mm
K	Height of bucket pivot (max.)	3.686 mm
L	Load-over height	3.325 mm
M	Dumping height	2.758 mm
N	Operating distance for M	1.009 mm
O	Digging depth	128 mm
P	Total width	1.990 mm
Q	Track width	1.422 mm
S	Ground clearance	375 mm
T	Maximum radius external	4.172 mm
U	Radius at the outer edge	3.683 mm
V	Inside turning radius	1.878 mm
W	Inclination angle	42 °
X	Rollback angle at max. lifting height	38 °
Y	Dumping angle (max.) (max.)	28 °
Z	Rollback angle (on the ground)	44 °



5080

Wheel loader

Standard components

Engine

- Perkins 854F-E34TA (55.4 kW / 75 hp)

Drive system

- Planetary axle PA1422/2
- Hydrostatic 4 wheel drive, travel direction can be selected via joystick
- Service brake: Disc brake (combined with parking brake)
- Central service and parking brake in the drive train acting on all 4 wheels
- 100% differential lock, electric-hydraulically connectable on front and rear axle
- Tires 550 / 45 - 22.5 AS ETO

Steering system

- Hydraulic articulated pendulum steering, 12° oscillating angle

Hydraulics

- 3rd control circuit in front electrically proportional in parallel via joystick, including double notch
- Hydraulic oil cooler
- Floating position for lift cylinder
- Oil volume adjustment via jog dial control element

Operator's cab

- Comfort cabin with heater and ventilation, ROPS / FOPS tested
- Laterally tiltable operator's cab
- Comfort seat with safety belt, fully suspended, weight, back and horizontal adjustment
- Hydraulically pilot controlled joystick with motion direction control and integrated touch button for differential lock
- Adjustable steering wheel (tilt), armrest on right

Kinematics

- Z kinematics

Other

- Work lights (2 front, 2 rear)
- Lighting equipment according to Road Traffic Regulations
- Operating hour meter
- Battery isolator switch
- Fuel display
- Hydraulic quickhitch system for attachments
- Water filling, front tyres



5080

Wheel loader

Options

Engine

- Perkins 854F-E34TA (90 kW / 122 hp)
- Manual throttle
- Engine pre-heater (coolant), hydraulic oil pre-heater 230 V

Operator's cab

- Air-conditioning system
- Air-suspended comfort seat
- Heated seat
- Radio
- Cabin plug receptacle 230 V
- Protective grating for front window
- Storage box with bottle holder (left next to the operator's seat)

Lighting

- LED work lights (2 front, 2 rear)
- MEGA work lights (2 front, 2 rear)
- Rotating beacon

Drive system

- Speed increase to 30 km/h
- Speed increase to 40 km/h
- Hand inching (creep speed controller)

Hydraulics

- Unpressurised reverse travel (front / rear)
- 3rd flow sharing control circuit (100 l)
- 3rd flow sharing control circuit (115 l)
- 4 flow sharing control circuit (100 l)
- 4 flow sharing control circuit (115 l)
- Dual-acting high flow, load-sensing performance hydraulics (150 l/min)
- 3rd control circuit, electrically, proportionally, serial
- 4 additional control circuit electrically proportional in parallel
- Hydraulic connection in rear is dual-acting via reversing valve (l/min like 3rd control circuit in front)
- Dual-acting hydraulic connection in rear (63 l/min) (two couplings), including separate control valve
- 2x hydraulic connection in rear (63 l/min) dual acting (four couplings), including separate control valve

Electrical connections

- Plug receptacle in front, triple-pole (dual function)



- Front plug receptacle, 7-pole for lighting of front attachments
- Plug receptacle for rear attachments, triple-pole
- Plug receptacle for rear attachments, 7-pin

Other

- Reversing alarm
- Combination case with warning triangle and first-aid kit
- Tool box
- Set of tools
- Fully automatic central lubrication unit
- Custommade paint finish
- Hand lever grease gun
- Lifting arm damping
- Lowering brake valve (hose burst valves for lift and tipping cylinders)
- Drive interlock (operation via coded ignition switch key)
- Cardan shaft protection
- Bio-hydraulic oil (HLP Synt46)
- Fire extinguisher 2 kg
- Isolator switch 2 circuits (disconnection of on-board voltage supply and generator)
- Number plate bracket
- TÜV expert's report for road travel (addendum in vehicle documentation)
- Automatic trailer coupling
- "Hitch" trailer coupling
- Approval as self-propelled work machine with ball hitch
- Official approval for road use
- Water-filled tyres

Please note

that product availability can vary from country to country. It is possible that information / products may not be available in your country. More detailed information on engine power can be found in the operator's manual; the stated power may vary due to specific operating conditions.

Subject to alterations and errors excepted. Applicable also to illustrations.

Copyright © 2017 Weidemann GmbH.