



T4512

Telehandler



Technical specifications

	Small engine	Large engine
Engine data		
Manufacturer	Yanmar	Yanmar
Engine type	3TNV82A	3TNV84T
Cylinders	3	3
Engine performance (max.) kW (hp)	22.6 (31)	29.6 (40)
at rpm (max.) rpm	3000	2800
Cubic capacity cm ³	1331	1496
Cooling system	Water	Water



	Small engine	Large engine
Electrical system		
Operating voltage V	12	12
Battery Ah	77	77
Alternator A	55	55
Weights		
Operating weight (standard) kg	2700	2700
Payload (max.) kg	1.200	1.200
Vehicle data		
Axle	PAL 1155	PAL 1155
Cab (optional)	FSD (cab)	FSD (cab)
Ground speed (optional) km/h	0 - 20	0 - 20
Speed stages	2	2
Fuel tank capacity l	25	25
Hydraulic oil tank capacity l	40	40
Total carriage rotation angle °	148	148
Total pivoting angle °	14	14
Steering angle (max.) °	2 x 38	2 x 38
Lifting cylinder: raise / lower sec	6.1 / 4.8	6.1 / 4.8
Extension cylinder: extend / retract sec	4.9 / 3.9	4.9 / 3.9
Tipping cylinder: crowd / tilt sec	2.6 / 2.3	2.6 / 2.3
Hydraulic system		
External services - Operating pressure bar	360	360
Steering hydraulics - Oil flow (optional) l/min	42 (75)	40 (70)
Steering hydraulics - Operating pressure bar	220	220
Drive		
Type of drive	Hydrostatic	Hydrostatic
Traction drive	Universal joint shaft	Universal joint shaft
Noise values		
Average sound power level L _{WA} dB(A)	97,7	99,3
Guaranteed sound power level L _{WA} dB(A)	101	101
Specified sound pressure level L _{pA} dB(A)	84	84

FSD = canopy

Second values measured without vls (vertical lift system)



Vibrations (weighted average effective value)

Hand-arm vibrations: The hand-arm vibrations are no more than 2.5 m/s²

Whole body vibrations: This machine is equipped with a driver's seat that meets the requirements of EN ISO 7096:2000.

When the loader is properly used, the whole body vibrations vary from below 0.5 m/s² up to a short-term maximum value.

It is recommended to use the values specified in the table when calculating the vibration values according to ISO/TR 25398:2006. At the same time the actual use conditions have to be taken into consideration.

telehandlers, like wheeled loaders, are to be classified by operating weight.

Type of loader	Typical operating conditions	Average value			Standard deviation (s)		
		$1.4 \cdot a_{w,eqx}$	$1.4 \cdot a_{w,eqy}$	$a_{w,eqz}$	$1.4 \cdot s_x$	$1.4 \cdot s_y$	s_z
		[m/s ²]	[m/s ²]	[m/s ²]	[m/s ²]	[m/s ²]	[m/s ²]
Compact wheeled loader (operating weight < 4,500 kg)	Load & carry (load and transport work)	0.94	0.86	0.65	0.27	0.29	0.13
wheeled loader (operating weight > 4,500 kg)	Load & carry (load and transport work)	0.84	0.81	0.52	0.23	0.2	0.14
	Application in extraction (harsh application conditions)	1.27	0.97	0.81	0.47	0.31	0.47
	Transfer drive	0.76	0.91	0.49	0.33	0.35	0.17
	V-operation	0.99	0.84	0.54	0.29	0.32	0.14



T4512

Telehandler

Dimensions

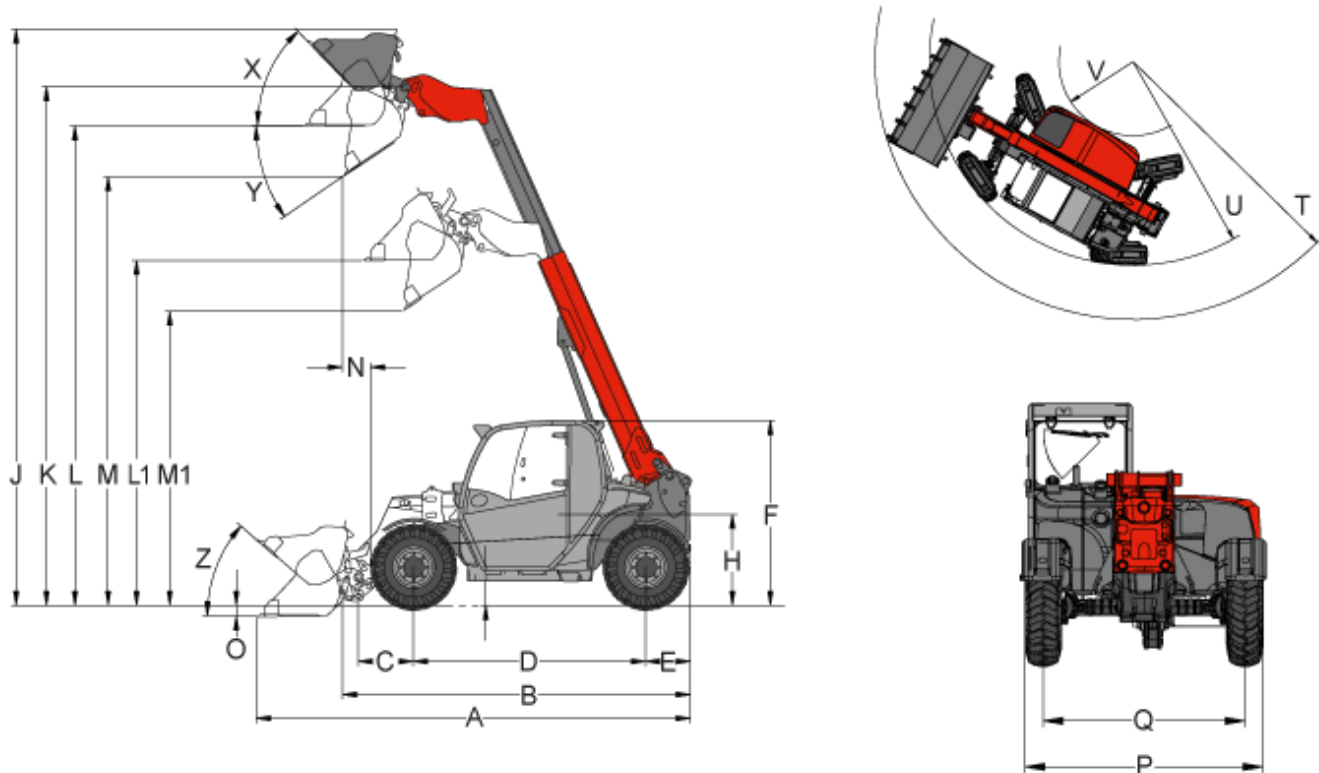

Small engine

A	Total length	3.879 mm
B	Total length (without bucket)	2.916 mm
C	Axle middle to bucket pivot pin	425 mm
D	Wheelbase	1.920 mm
E	Rear overhang	391 mm
F	Height to top of overhead guard fixed	1.940 mm



	Height to top of cabin	1.940 mm
H	Seat top height	974 mm
J	Total working height	5.211 mm
K	Height of bucket pivot (max.)	4.503 mm
L1	Load-over height Retracted telescopic arm	2.909 mm
L	Load-over height Extended telescopic arm	4.123 mm
M1	Dumping height Retracted telescopic arm	2.375 mm
M	Dumping height Extended telescopic arm	3.589 mm
N	Operating distance for M	543 mm
O	Digging depth	92 mm
P	Total width	1.560 mm
Q	Track width	1.296 mm
S	Ground clearance	290 mm
T	Maximum radius external	3.398 mm
U	Radius at the outer edge	2.607 mm
V	Inside turning radius	821 mm
X	Rollback angle at max. lifting height	52 °
Y	Dumping angle (max.) (max.)	31 °
Z	Rollback angle (on the ground)	44 °

All values with a standard bucket and standard tyres



T4512

Telehandler

Standard components

Engine

- Yanmar 3TNV82A (22.6 kW / 31 hp)

Drive

- Planetary axle PAL 1155
- Hydrostatic all-wheel drive, travel direction can be selected via joystick
- Service brake: Hydrostatic drive system acting on all 4 wheels (wear-free)
- Central service and parking brake in the drive train acting on all 4 wheels
- tyres 10.0 / 75 - 15.3 AS ET-40

Steering system

- Hydraulic all-wheel steering, steering angle 2 x 38°

Hydraulics

- 3rd Control circuit front DN10
- Hydraulic oil cooler
- VLS (Vertical Lift System)

Driver's cab

- Canopy with retaining system ROPS / FOPS tested, window on right side
- Comfort seat with safety belt and air cushioning
- Joystick with direction control switch and integrated touch button for telescoping function

Other

- Operating hour meter
- battery isolator switch
- Fuel display
- Mechanical quick-change system for attachments



T4512

Telehandler

Options

Engine

- Yanmar 3TNV84T (29.6 kW / 40 hp)
- Manual throttle
- Engine pre-heating

Driver's cab

- Front window complete with wiper
- Complete rear window
- Cabin, including heating and ventilation
- Adjustable steering column
- Air-suspended comfort seat

Lighting

- Working lights, 2 front, 1 rear
- Working light, 1 on telescopic arm
- LED working lights, 2 front, 1 rear
- LED working light, 1 on telescopic arm
- Lighting according to StVZO, including 7-pin plug receptacle
- rotating beacon

Axles / drive

- 100% differential lock (front and rear axle)
- 45% lamellas self-locking differential
- Hand inching (creep speed controller)

Hydraulics

- Unpressurised reflux (front)
- 3rd comfort control circuit
- Reversing valve in front on 3rd control circuit (3rd control circuit with 4 connections)
- Single-acting high flow
- Faster plug-in connector (machine or attachment side)
- Notch for joystick (single / double)
- Hydraulic connection in rear (dual acting)
- Three-point rear tool holder
- PTO 540 1/min (10 kW)

Electrical connections

- Plug receptacle in front, triple-pole (dual function)



Other

- Hydraulic quick-change system for attachments
- Small counterweight (-148 kg)
- back-up alarm
- Stacker coupling hitch device
- Hitch device "Rockinger"
- Hand lever grease gun
- Tool box
- Technical Inspection Authority expert's report
- Central lubrication system
- custom-made paintwork

Please note

that product availability can vary from country to country. It is possible that information / products may not be available in your country. More detailed information on engine power can be found in the operator's manual; the stated power may vary due to specific operating conditions.

Subject to alterations and errors excepted. Applicable also to illustrations.

Copyright © 2017 Weidemann GmbH.