



T5522

Telehandler



Technical specifications

Engine data

Manufacturer	Perkins
Engine type (optional)	404D-22 (404F-22T)
Cylinders	4
Engine performance (max.) /optional	36.3 / 44.7 (49 / 61) kW (hp)
at rpm (max.)	2800 rpm
Cubic capacity	2216 cm ³
Cooling system	Water

Electrical system

Operating voltage	12 V
-------------------	------



Battery	77 Ah
Alternator	85 A
Weights	
Operating weight (standard)	4200 kg
Payload (max.)	2.200 kg
Vehicle data	
Axle	PAL 1530
Cab	Cab
Ground speed (optional)	0-20 (30) km/h
Speed stages	2
Fuel tank capacity	70 l
Hydraulic oil tank capacity	55 l
Total carriage rotation angle	144 °
Total pivoting angle	16 °
Steering angle (max.)	2 x 40 °
Lifting cylinder: raise / lower	6.2/4.2 sec
Extension cylinder: extend / retract	5.1/2.5 sec
Tipping cylinder: crowd / tilt	3.1/2.2 sec
Hydraulic system	
External services - Operating pressure	450 bar
Steering hydraulics - Oil flow (optional)	70 (106) l/min
Steering hydraulics - Operating pressure	225 bar
Drive	
Type of drive	Hydrostatic
Traction drive	Universal joint shaft
Noise values	
Guaranteed sound power level L _{WA}	103 dB(A)
Specified sound pressure level L _{pA}	82 dB(A)

Second values measured without vls (vertical lift system)

Vibrations (weighted average effective value)

Hand-arm vibrations: The hand-arm vibrations are no more than 2.5 m/s²

Whole body vibrations: This machine is equipped with a driver's seat that meets the requirements of EN ISO 7096:2000.



When the loader is properly used, the whole body vibrations vary from below 0.5 m/s² up to a short-term maximum value.

It is recommended to use the values specified in the table when calculating the vibration values according to ISO/TR 25398:2006. At the same time the actual use conditions have to be taken into consideration.

telehandlers, like wheeled loaders, are to be classified by operating weight.

Type of loader	Typical operating conditions	Average value			Standard deviation (s)		
		1.4*a _{w,eqx} [m/s ²]	1.4*a _{w,eqy} [m/s ²]	a _{w,eqz} [m/s ²]	1.4*s _x [m/s ²]	1.4*s _y [m/s ²]	s _z [m/s ²]
Compact wheeled loader (operating weight < 4,500 kg)	Load&&carry (load and transport work)	0.94	0.86	0.65	0.27	0.29	0.13
wheeled loader (operating weight > 4,500 kg)	Load&&carry (load and transport work)	0.84	0.81	0.52	0.23	0.2	0.14
	Application in extraction (harsh application conditions)	1.27	0.97	0.81	0.47	0.31	0.47
	Transfer drive	0.76	0.91	0.49	0.33	0.35	0.17
	V-operation	0.99	0.84	0.54	0.29	0.32	0.14



T5522

Telehandler

Dimensions

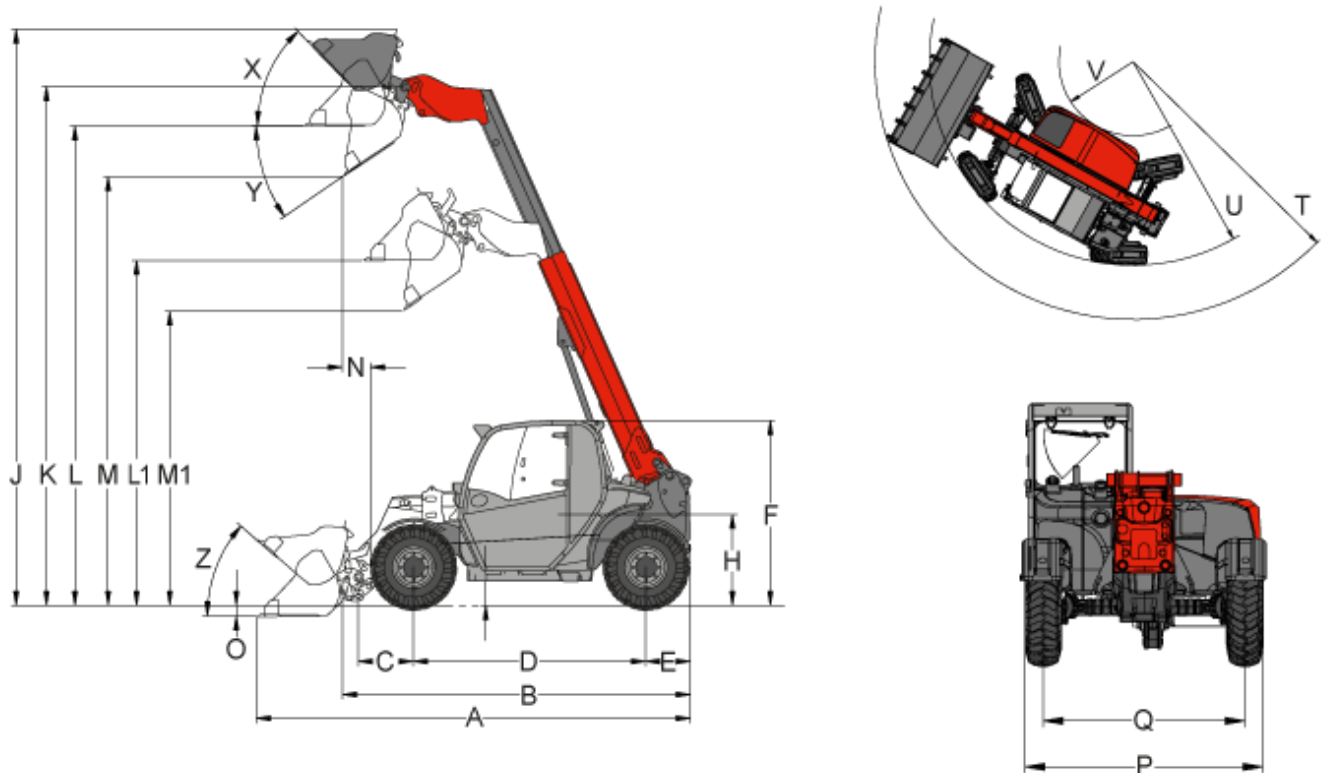

A	Total length	4.576 mm
B	Total length (without bucket)	3.747 mm
C	Axle middle to bucket pivot pin	581 mm
D	Wheelbase	2.449 mm
E	Rear overhang	472 mm
F	Height to top of cabin	1.950 mm
H	Seat top height	962 mm



J	Total working height	6.074 mm
K	Height of bucket pivot (max.)	5.471 mm
L1	Load-over height Retracted telescopic arm	3.638 mm
L	Load-over height Extended telescopic arm	5.056 mm
M1	Dumping height Retracted telescopic arm	3.103 mm
M	Dumping height Extended telescopic arm	4.520 mm
N	Operating distance for M	293 mm
O	Digging depth	111 mm
P	Total width	1.808 mm
Q	Track width	1.530 mm
S	Ground clearance	256 mm
T	Maximum radius external	4.153 mm
U	Radius at the outer edge	3.281 mm
V	Inside turning radius	1.193 mm
X	Rollback angle at max. lifting height	46,5 °
Y	Dumping angle (max.) (max.)	34,5 °
Z	Rollback angle (on the ground)	41 °

All values with a standard bucket and standard tyres



T5522

Telehandler

Standard components

Engine

- Perkins 404 D-22 (36.3 kW / 49 hp)

Drive

- Planetary axle PAL 1530
- Hydrostatic all-wheel drive, travel direction can be selected via joystick
- Service brake: Hydrostatic drive system acting on all 4 wheels (wear-free)
- Central service and parking brake in the drive train acting on all 4 wheels
- tyres 10.5 / 80 - 18 AS ETO

Steering system

- Hydraulic all-wheel steering, steering angle 2 x 40°

Hydraulics

- 3rd control circuit front, proportionally via joystick
- Hydraulic oil cooler
- VLS (Vertical Lift System)

Driver's cab

- Comfort cabin with heating and ventilation, ROPS / FOPS tested
- Comfort seat with safety belt and air cushioning
- Hydraulic pilot operated joystick with direction control switch and proportional telescoping function



Other

- Operating hour meter
- battery isolator switch
- Fuel display
- Working lights (2 front, 2 rear)
- Mechanical quick-change system for attachments



T5522

Telehandler

Options

Engine

- Perkins 404 F-22 T (44.7 kW / 61 hp)
- Manual throttle
- Engine pre-heating

Driver's cab

- Air conditioning
- Heated seat
- Radio
- Adjustable steering column
- Air-suspended comfort seat

Lighting

- Working light, (1 on telescopic arm)
- LED working lights (2 front, 2 rear)
- LED working light, (1 on telescopic arm)
- Lighting according to Road Traffic Regulations
- rotating beacon

Axles / drive

- 100% differential lock (front and rear axle)
- Speed increase to 30 km/h
- Hand inching (creep speed controller)
- Crab steering



Hydraulics

- Unpressurised reflux (front or rear)
- 3rd control circuit, electrically, proportionally, serial
- Reversing valve in front on 3rd control circuit (3rd control circuit with 4 connections)
- 4th control circuit, electrically double-acting
- Faster plug-in connector (machine or attachment side)
- Single-acting high flow
- Hydraulic connection in rear (dual acting)
- Three-point rear tool holder
- PTO 540 1/min (19 kW)

Electrical connections

- Plug receptacle in front, 7-pin
- Plug receptacle in front, triple-pole (dual function)
- Plug receptacle in rear, 7-pin

Other

- Hydraulic quick-change system for attachments
- back-up alarm
- Ball hitch device
- Stacker coupling hitch device
- Additional mirror for hitch device
- Hand lever grease gun
- Combination case (warning triangle / first aid kit)
- Tool box
- Technical Inspection Authority expert's report
- Load vibration suppression
- Central lubrication system
- custom-made paintwork



Please note

that product availability can vary from country to country. It is possible that information / products may not be available in your country. More detailed information on engine power can be found in the operator's manual; the stated power may vary due to specific operating conditions.

Subject to alterations and errors excepted. Applicable also to illustrations.

Copyright © 2017 Weidemann GmbH.