



T6027

Telehandler



Technical specifications

Engine data

Manufacturer	Kohler
Engine type	KDI 2504 TCR
Cylinders	4
Engine performance (max.)	55.4 (74) kW (hp)
at rpm (max.)	2600 rpm
Cubic capacity	2482 cm ³
Cooling system	Water

Electrical system

Operating voltage	12 V
-------------------	------



Battery	100 Ah
Alternator	80 A
Weights	
Operating weight (standard)	5225 kg
Payload (max.)	2.700 kg
Vehicle data	
Axle	PAL 1720
Cab	Cabin
Ground speed	0- 20 (30) km/h
Speed stages	3
Fuel tank capacity	100 l
Hydraulic oil tank capacity	75 l
Total carriage rotation angle	150 °
Total pivoting angle	20 °
Steering angle (max.)	2x38 °
Hydraulic system	
External services - Operating pressure	450 bar
Steering hydraulics - Oil flow	90 l/min
Steering hydraulics - Operating pressure	240 bar
Drive	
Type of drive	Hydrostatic
Traction drive	Universal joint shaft
Noise values	
Average sound power level L _{WA}	103 dB(A)
Guaranteed sound power level L _{WA}	104 dB(A)
Specified sound pressure level L _{pA}	80 dB(A)

Second values measured without vls (vertical lift system).

Vibrations (weighted average effective value)

Hand-arm vibrations (HAV): The hand-arm vibrations are no more than 2.5 m/s²

Whole body vibrations: This machine is equipped with an operator's seat that meets the requirements of EN ISO 7096:2000.



When the loader is properly used, the whole body vibrations vary from below 0.5 m/s² up to a short-term maximum value.

It is recommended to use the values specified in the table when calculating the vibration values according to ISO/TR 25398:2006. At the same time, the actual use conditions have to be taken into consideration.

Telehandlers, like wheel loaders, are to be classified by operating weight.

Type of loader	Typical operating conditions	Average value			Standard deviation (s)		
		1.4*a _{w,eqx} [m/s ²]	1.4*a _{w,eqy} [m/s ²]	a _{w,eqz} [m/s ²]	1.4*s _x [m/s ²]	1.4*s _y [m/s ²]	s _z [m/s ²]
Compact wheel loader (operating weight < 4,500 kg)	Load&&carry (load and transport work)	0.94	0.86	0.65	0.27	0.29	0.13
Wheel loader (operating weight > 4,500 kg)	Load&&carry (load and transport work)	0.84	0.81	0.52	0.23	0.2	0.14
	Application in extraction (harsh application conditions)	1.27	0.97	0.81	0.47	0.31	0.47
	Transfer drive	0.76	0.91	0.49	0.33	0.35	0.17
	V-operation	0.99	0.84	0.54	0.29	0.32	0.14



T6027
Telehandler

Dimensions

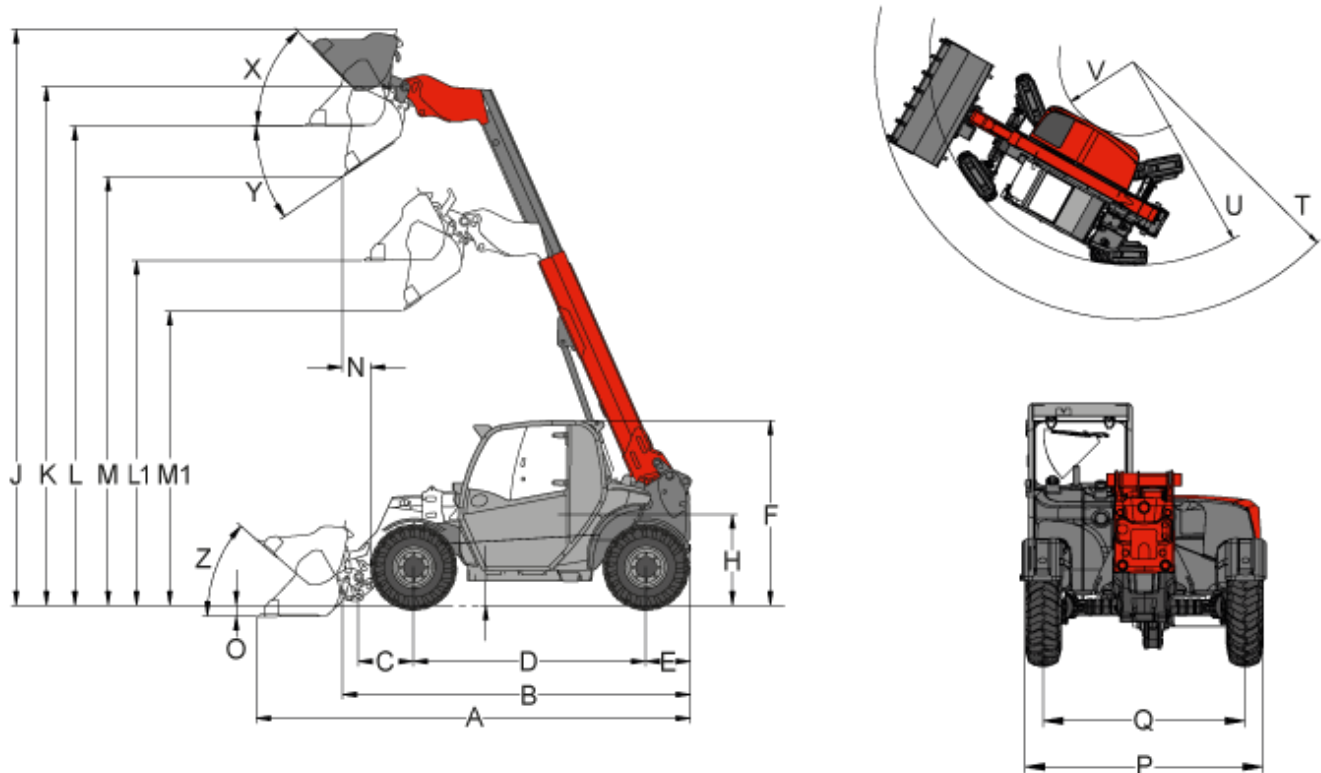

	Standard lightweight bucket	2.000 mm
A	Total length	4.958 mm
B	Total length (without bucket)	4.400 mm
C	Axle middle to bucket pivot pin	1030 mm
D	Wheelbase	2.650 mm
E	Rear overhang	720 mm
F	Height to top of cabin - low-profile	1.980 mm



F	Height to top of cabin - high-profile	2.100 mm
H	Seat top height	1.025 mm
J	Total working height	6.580 mm
K	Height of bucket pivot (max.)	6.080 mm
L1	Load-over height Retracted telescopic arm	3.730 mm
L	Load-over height Extended telescopic arm	5.600 mm
M1	Dumping height Retracted telescopic arm	3.450 mm
M	Dumping height Extended telescopic arm	5.280 mm
N	Operating distance for M	680 mm
O	Digging depth	150 mm
P	Total width	1.960 mm
Q	Track width	1.660 mm
S	Ground clearance	250 mm
T	Maximum radius external	4.500 mm
U	Radius at the outer edge	3.670 mm
V	Inside turning radius	1.700 mm
X	Rollback angle at max. lifting height	45 °
Y	Dumping angle (max.) (max.)	40 °
Z	Rollback angle (on the ground)	45 °

All values with a standard bucket and standard tyres



T6027

Telehandler

Standard components

Motor

- KDI 2504 TCR (55.4 kW/75 hp), exhaust emission standard level III B
- Exhaust after-treatment: DOC (diesel oxidation catalytic converter)

Drive system

- Planetary axle PAL 1720
- Hydrostatic 4 wheel drive, electronically regulated, travel direction can be selected via joystick
- Service brake: Hydrostatic drive system acting on all 4 wheels (wear-free)
- Central service and parking brake in the drive train acting on all 4 wheels
- Tyres 12.5-18 MPT-01

Steering system

- Hydraulic all-wheel steering, steering angle 2 x 38°
- 3 steering modes available: All-wheel steering, front axle steering and crab steering

Hydraulics

- 3rd control circuit front, proportionally via joystick
- Continuous function for 3rd control circuit connectable via keypad
- Gear pump with load-independent flow distribution (LUDV)
- Hydraulic oil cooler
- Driver assistance system vls (Vertical Lift System), 3 modes available: Bucket mode, stacking mode and manual mode

Operator's compartment

- Comfort cabin with heater and ventilation, ROPS/FOPS tested (acoustically insulated, vibration-damped)



- Comfort seat with safety belt
- Hydraulic pilot operated joystick with forward-reverse control switch and proportional telescoping function
- Rear window can be opened
- Left side window can be raised in 2 positions
- Hanging pedals
- Bottle holder and storage compartments
- Window wiper in front and rear

Other

- Operating hour meter
- Battery isolator switch
- Fuel display
- Lighting according to Road Traffic Regulations
- 1 work light in front, 1 work light at rear
- Mechanical quickhitch system for attachments
- Co-driven mudguard on all wheels
- Final position dampening in the telescopic cylinder



T6027

Telehandler

Options

Motor

- Exhaust after-treatment: DPF (diesel particulate filter)
- Engine pre-heater (coolant) + hydraulic oil pre-heater 230 V
- Low pressure pre-filter for intake air
- Recoil Starter

Operator's compartment

- Air-conditioning system
- Radio
- Raised cabin for better circumferential visibility (high machine 2100 mm)
- Adjustable steering column
- Air-suspended comfort seat
- Protective grating for windscreen
- Cab window right and rear, heated (with automatic shut-off)

Lighting

- Work light, (2 in front on telescopic arm)
- Additional work lights (1 front, 1 rear)
- LED work lights (2 front, 1 rear)
- LED work light, (2 in front on telescopic arm)
- Rotating beacon

Axles/drive

- Differential lock 100%
- Speed increase to 30 km/h
- Hand inching (low-speed control) and hand throttle

Hydraulics

- Unpressurised reverse travel (front)
- Reversing valve in front on 3rd control circuit (3rd control circuit with 4 connections)
- Pressure release of 3rd control circuit outside on telescopic arm
- Tipper connection
- Rear hydraulic connection, additional double-acting, including separate control valve

Electrical connections

- Front plug receptacle, 7-pole for lighting front attachments
- Plug receptacle in front, 7-pole for various functions
- 7-pole plug receptacle in rear for lighting rear attachments



Trailer and recovery jigs

- Stacker coupling hitch device
- Automatic trailer coupling
- Height adjustable trailer coupling, ball coupling and semi-automatic
- Auto-hitch trailer coupling
- Hydraulic control circuit for auto-hitch
- Hydraulic control circuit for auto-hitch, including dumper connection
- Hydraulic control circuit for auto-hitch, including dumper connection and double-acting hydraulic connection
- Hydraulic trailer brake valve
- Additional mirror for trailer coupling

Other

- Hydraulic quickhitch system for attachments
- Toolbox, attachment set
- Tilting cylinder lock
- Reversing alarm
- Drive interlock integrated in ignition switch key
- Camera visibility front right
- Reversing camera
- Undersealant
- Central lubrication system
- Lifting arm damping
- Automatic bucket return
- Custommade paint finish

Please note

that product availability can vary from country to country. It is possible that information / products may not be available in your country. More detailed information on engine power can be found in the operator's manual; the stated power may vary due to specific operating conditions.

Subject to alterations and errors excepted. Applicable also to illustrations.

Copyright © 2017 Weidemann GmbH.